

2010  
Catalog

# WOODCRAFT

*Technologies, Inc.*

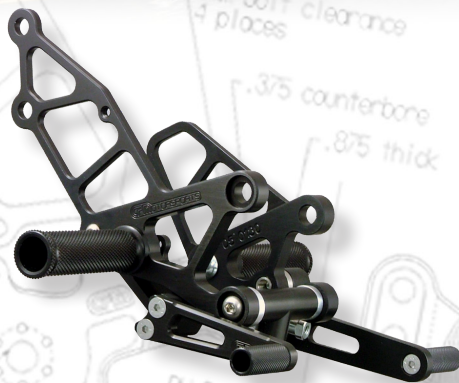

*Products for sportbikes that make sense!*



Woodcraft Technologies, Inc. is a company designed to cater to the needs of racers, trackday riders and the sportbike enthusiast. We work hard to make customer service a top priority and have trained our sales staff to provide the fast, knowledgeable service that racers demand and customers expect.

The first consideration for any Woodcraft product is its' ability to withstand the rigors of the racetrack, no fragile pieces of art here! Our primary goal is to build products that work on the track, look great on the street, and are sold at a price riders can afford. Most of our products are repairable and replaceable in innovative ways that save time, and money, after a crash.

In short: **if we can't make a better product, we won't make it at all!**

As you will see from the pictures contained within, we are a group of enthusiasts who love what we do. Our staff is full of racers, riders and people who have been around the sport for years. I have been riding and racing since I was three years old and I make a concerted effort to put my 20 years of racing experience into the design of each of the products with the Woodcraft name.

Thanks for checking us out.

## Eric Wood



### Eric Wood

- 20 Years Professional Racing Experience
- Head Instructor: Penguin Racing School
- Mechanical Engineer
- Motorcycle nut



**Hand Controls** **3**

3-piece Split Clip-Ons  
Clip-On Accessories  
Clip-On Risers  
OEM fork sizing chart

**Foot Controls** **6**

Rearset Kits  
Brake Switches & Return Springs  
3-piece Pedals

**Case Covers** **12****Frame Sliders** **15****Shark Guard** **17****Tire Warmers** **18**

Dual Temp  
Push Button Digital

**Wheel Stands** **19**

Solo Operation Front Stand  
Front Stand pin application chart  
Rear Stands (spool & pad)  
Swingarm Spools

**Armour Bodies** **23**

Bodywork  
Custom Seat Foam & Dzus fasteners

**Klucky Pucks** **26****Ceramic Bearings** **27**

Wheel Kits  
Engine Kits

**Apparel & Accessories** **28****Thank You** **29****Notes / Terms & Conditions** **30**

## 3-piece Split Clip-On

The motivation behind the **Woodcraft 3-piece Split Clip-Ons** is simple: installing, servicing, and removing clip-ons can be a real pain and eat up valuable time at the track! With our 3-piece design we've eliminated the need to disassemble the front-end to service your Clip-Ons.

Lightweight, great looks, improved strength, adjustability and easy installation make Woodcraft 3-piece Split Clip-Ons an essential addition to any sportbike.

### Ease of Installation

Woodcraft's trademark 2-piece body clamp installs easier and faster than the competition. You will never have to disassemble your front end again just to change bars.

### Economical

The universal replacement bars can pay for themselves in one crash! Most OEM bars are expensive 1-piece assemblies and require complete front end disassembly to replace.

### Lightweight

Extra time was taken on these pieces to make them lightweight, strong and great looking.

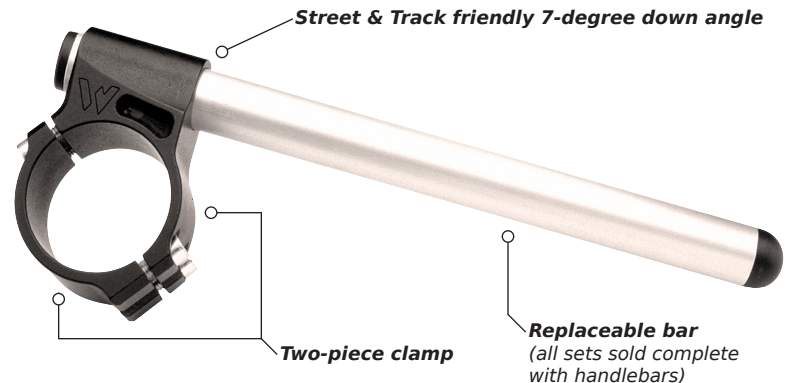

Clip-On Application (mm) & Part Number					
29mm	12-0129	37mm	12-0137	50mm	12-0150
30mm	12-0130	38mm	12-0138	51mm	12-0151
31mm	12-0131	41mm	12-0141	52mm	12-0152
32mm	12-0132	41mm Kawi650R	12-0141S	53mm	12-0153
33mm	12-0133	43mm	12-0143	53.5mm	12-0153S
34mm	12-0134	45mm	12-0145	54mm	12-0154
35mm	12-0135	46mm	12-0146	03-04 GSXR1000	12-0250
36mm	12-0136	48mm	12-0148	06+ GSXR600/750	12-0350



### Notes-

> **Special Clip-On sizes are available:** We can modify our standard clip-ons for applications between 29mm to 55mm.

> Woodcraft's are the *only* clip-ons that fit the **03-04 Suzuki GSX-R 1000** (track only) and **06+ Suzuki GSX-R 600/750's** (street & track) properly. Due to the fork taper regular clip-ons cannot grasp the fork leg correctly. With its internal step, Woodcraft's exclusive 2-piece clamp ensures a secure grip!

> For special applications please call us: **978-297-2977**

## Clip-On Accessories

Accessory & Part Number	
Replacement Bar (each)	13-0100
1" Harley Bar	13-0101
Bar Mount Res. Bracket	12-3200
GSX-R Brake Res. Bracket	
600/750 to 2005 1000 to 2004	12-3240
600/750 2006+ 1000 2005+	12-3245

### Replacement Handlebar

All Woodcraft Clip-Ons feature a easily removable and replaceable handlebar tube for quick and cost-effective fixes in case of a crash.

### Bar Mount Brake Reservoir Bracket

Built for bikes that cannot mount the remote brake reservoir at the pinch bolt mounting point this trick bracket will do the job. This bracket can be oriented either parallel or perpendicular to the bar.

**Note-** All Riser Clip-Ons (p.4) require this style of mount.

### GSX-R Brake Reservoir Bracket

For Suzuki GSX-R models that use a remote brake fluid reservoir these simple brackets bolt through the top triple clamp pinch bolt and provide a solid mounting point for OEM reservoir.

**Note-** These are **not compatible** with Woodcraft Riser Clip-Ons.



*"My Woodcraft clip-ons feel excellent and have withstood multiple crashes.."*



# Hand Controls Clip-On Risers

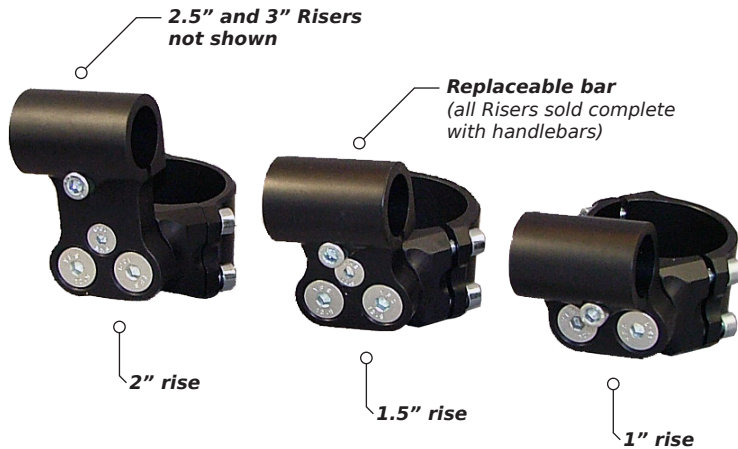

## Adjustability

Woodcraft's new clip-on risers consist of special indexed risers that are easily changed and come in 1", 1.5", 2", 2.5", and 3" rises over a standard Woodcraft Clip-On.

## Necessity

Several models have very tight clearances from the factory. Our Woodcraft risers are crafted for the perfect fit in these applications.

## Comfort

Many riders find stock sportbike ergonomics uncomfortable for real-world riding. The Woodcraft risers allow you to custom tailor the fit and feel of your motorcycle resulting in a more enjoyable ride.

Riser Application (mm) & Part Number										
41mm		48mm		50mm		53mm		Kawasaki Ninja / EX models		BMW S1000RR
1" rise	12-1541	1" rise	12-1548	1" rise	12-1550	1" rise*	12-1553	EX250 1988-07*	12-0236	12-5750
1.5" rise	12-2541	1.5" rise	12-2548	1.5" rise	12-2550	1.5" rise	12-2553	EX250 2008+	12-4537	
2" rise	12-3541	2" rise	12-3548	2" rise	12-3550	2" rise	12-3553	EX500 1987-93*	12-0236	
2.5" rise	n/a	2.5" rise	12-4548	2.5" rise	12-4550	2.5" rise	12-4553	EX500 1994+*	12-0237	
3" rise	n/a	3" rise	12-5548	3" rise	12-5550	3" rise	12-5553			

\* = standard riser that bolts in OEM location



### Notes-

> The rise on these parts is referenced from the standard Woodcraft clip-on. When ordering riser-style clip-ons it is very important to consider clearance issues at full lock steering.

> When evaluating your motorcycle for fitment it is important to note that the center of the handlebar on these risers sits about one (1) inch forward of the edge of the fork tubes.



## Case Studies

### 2010 BMW S1000RR

Woodcraft built a all-new Riser from the ground-up and designed just for this beautiful bike. For street applications, the OEM fairing bracket does not allow for the height of the bar to be changes, but Woodcraft's BMW change the bars angle from the nearly 12 degree stock slope to a muc h more comfortable 7 degrees. (12-0750)

### 2008+ Kawasaki Ninja 250

The new Ninja 250 is a great bike for both the street and track, new or experienced riders. We sat down and designed a set of risers just for this cool machine. The result is a set of 37mm Risers with a rider-friendly 5-degree angle that offer a vastly better racing position while not interfering with the gauges, tank and fairing. (12-4537)

### Ducati 848 / 1098 / 1198

We found there are many riders that desire a higher handlebar position on the new generation Ducatis. Due to the cramped confines presented by the upper fairing design of these motorcycles we recommend our 1" risers. Our test riders have reported significant improvement in back, shoulder and wrist comfort! (12-1553)

## OEM fork sizing chart

Woodcraft does not guarantee clip-on fitment. This chart is a reference tool for fork tube sizes.

Aprilia	Size (mm)	Kawasaki	Size (mm)	Suzuki (continued)	Size (mm)
RS250	50	EX250 1988-07	EX36	GSX-R 600 1994-96	50
Showa w/radial calipers	51	EX250 2008+	37*	GSX-R 600 1997-03	45
Showa w/standard calipers	53	EX500 1987-93	EX36	GSX-R 600 2004-05	50
Ohlins	51	EX500 1994-04	EX37	GSX-R 600 2006+	50/48
<b>BMW</b>	<b>Size (mm)</b>	ZX6E/R 1993-97	41	GSX-R 750 1993-05	50
S1000RR	55	ZX6R 1998-02	46	GSX-R 750 2006+	50/48
<b>Buell</b>	<b>Size (mm)</b>	ZX6RR/636 2003-08	50	GSX-R 1000 2001-02	50/49
M2 Cyclone	43	ZX6R 2009+	51	GSX-R 1000 2003-04	50/49*
S1, S2, Lightning	54*	Ninja 650R 2006+	41S*	GSX-R 1000 2005+	50
Firebolt XB9 / XB12	54	ZX7R 1991+	52	GSX-R 1100	50
1125	54	ZX9R 1994-1997	52	<b>Triumph</b>	<b>Size (mm)</b>
<b>Ducati</b>	<b>Size (mm)</b>	ZX9R 1998+	46	675	50
Monster 620-1000SS	50	ZX10R 2004+	50	Speed Triple 2001-04	45
Monster S4-S4R	50	ZRX1100/1200	43	<b>White Brothers</b>	<b>Size (mm)</b>
748/749/916/996/998/999	53	<b>KTM</b>	<b>Size (mm)</b>	Superbike forks	54
848/1098/1198	53	Super Duke	48	<b>Yamaha</b>	<b>Size (mm)</b>
<b>Honda</b>	<b>Size (mm)</b>	RC8		FZR 400/600	38
CBR600 F1/F2/F3	41	<b>Ohlins</b>	<b>Size (mm)</b>	YZF 600 R6 1999-04	43
CBR600 F4/F4i	43*	Pre -1995 Superbike forks	51	YZF 600 R6 2005+	50
CBR600RR 2003-04	45	Superbike forks 1996-03	53.5	YZF 600 R6S 2006+	43
CBR600RR 2005+	48*	Superbike forks 2004+	52	YZF 750	50
NT647 Hawk	41	<b>Suzuki</b>	<b>Size (mm)</b>	YZF 1000 R1 to 2003	50
CBR900RR 1993-99	45	GS500	37	YZF 1000 R1 2004+	50*
CBR929/954	50*	SV650/S	41		
RC51	50	SV1000/S	46		
VTR1000F	41	TL1000S/R	50		
CBR1000RR	50	Hayabusa	50		

### Notes-

> Bikes marked with the (\*) symbol are known to be able to use Woodcraft 3-piece Split Clip-Ons for race applications yet may still require modification for correct clearances. In many cases Risers will solve the issue.

> There are some motorcycles that require modifications for proper clip-on fitment. You need to have correct amounts of clearance for the fairings, gauges, fuel tank, hose and cable routing, and other parts. If you have any questions about your specific model please call us at **978-297-2977** and we'll gladly assist you!



Chris Ormonde CCS #617



Dan Kapnis LRRS #319

*We support everything from Supersport R6's to Production Twin EX's!*



The foot controls are one of the most vital connections you have with your motorcycle. As a result Woodcraft designs and builds the best Rearsets available to ensure your motorcycle reacts the way you intend it to.

Our Rearset Kits use OEM pedals whenever possible to give you additional options and make spares easy to find. Our Full Kits include Woodcraft's 3-piece Pedals giving you a even stronger assembly and continuing our tradition of easy part replacement.

### Toughness

CFMotersports rearset kits are CNC machined from 6061-T6 billet aluminum and offer more than twice the durability of OEM rearset brackets.

### Confidence

Our trick knurled footpegs give supreme feedback and the best traction available today.

### Parts Accessibility

Nearly all kits will accept the OEM levers and footpegs for no-hassle spares. **Woodcraft will sell any individual piece for replacement parts.**

### Race Proven

Each kit is custom tailored for rise and setback. CFMotersports rearsets have proven their worth with **hundreds of National and Regional Championships.**

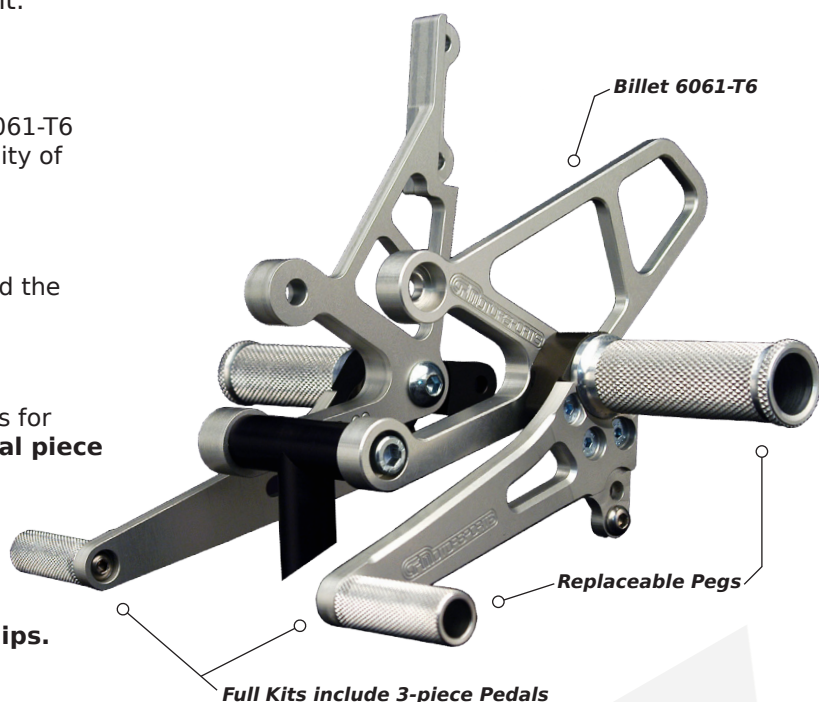

Legend
GP = GP shift only
STD = Standard shift only
No GP or STD = Can do either
BLK = Black
SLV = Silver
* = Optional heelguard avail.

Aprilia	Model	Rise Up & Back	Rearset Kit	Full Kit w/pedals	Repl. Pegs	Shift Rod
	RS125 GP	Adjustable	-----	05-0731B	06-0801	OEM
RS250 Cup	1", 1"	05-0700	05-0700B	06-0700	07-1225	
Mille 1998-03 / Tuono 2002-05	.5", .5"	05-0710	-----	06-0300	-----	
Mille 1998-03 / Tuono 2002-05 GP	.5", .5"	-----	05-0712 w/shift	06-0300	07-2600	
Tuono 2006+	.5", .5"	05-0720	-----	06-0300	-----	
Tuono 2006+ GP	.5", .5"	-----	05-0722 w/shift	06-0300	07-0675	
Factory/R 2004+	.5", .5"	05-0720	-----	06-0300	-----	
Factory/R 2004+ GP	.5", .5"	-----	05-0722 w/shift	06-0300	07-0675	
RSV4			TBA			

BMW	Model	Rise Up & Back	Rearset Kit	Full Kit w/pedals	Repl. Pegs	Shift Rod
	S1000RR STD	Adjustable	05-0750	05-0750B	06-0300	-----
S1000RR GP	Adjustable	05-0751	05-0751B	06-0300	-----	

Buell	Model	Rise Up & Back	Rearset Kit	Full Kit w/pedals	Repl. Pegs	Shift Rod
	XB9 / XB12 STD	Adjustable	-----	05-0800B	06-0800	07-2178
XB9 / XB12 GP	Adjustable	-----	05-0805B	06-0800	07-2178	
1125	Adjustable	-----	05-0810B	06-0800	07-2178	

*We do customer service! All individual kit pieces are available separately!*

# Foot Controls

## Rearset Kits

by CFM Motorsports



749 / 999

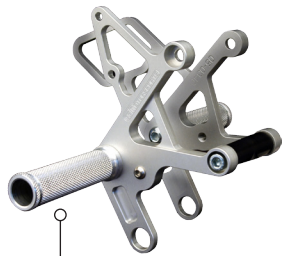

RC51

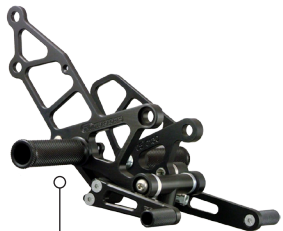

1998+ EX250

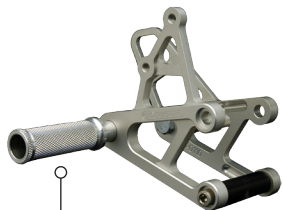

1998-02 ZX6R

### Ducati

Model	Rise Up & Back	Rearset Kit	Full Kit w/pedals	Repl. Pegs	Shift Rod
Monster 696 / 1100	2.5", 1"	-----	05-0660B	06-4801	07-2550
750 / 900SS 1991-98	1", 1"	05-0600	05-0600B	06-0300	07-2750
750 / 800 / 900 / 1000SS 1999-06	1", 1"	05-0620	05-0620B	06-0800	07-2550
748 / 916 / 996 / 998	Adjustable	05-0610 w/shift	05-0610B	06-0610	-----
749 / 999 BLK	Adjustable	05-0625 w/shift	05-0625B	06-4811	07-2750
848 / 1098 / 1198 BLK	Adjustable	05-0640	05-0640B	06-4811	OEM
848 / 1098 / 1198 SLV	Adjustable	05-0640A	05-0640BA	06-0811	OEM
Hypermotard BLK	Adjustable	-----	05-0650B	06-4801	07-0275

### Honda

Model	Rise Up & Back	Rearset Kit	Full Kit w/pedals	Repl. Pegs	Shift Rod
CBR600F2 / F3 1991-98	1", 1"	05-0300	-----	06-0300	07-0925
CBR600 F4 1999-2000	1.25", 1"	05-0330	05-0330B	06-0300 (L) 06-0301 (R)	07-0850
CBR600 F4i 2001-06	1.25", 1"	05-0330	05-0332B	06-0300 (L) 06-0301 (R)	07-0850
CBR600RR 2003-2006	1", 1.25"	05-0335 w/shift	05-0335B	06-0360	07-2875
CBR600RR 2007+ BLK	Adjustable	05-0338 w/shift	05-0338B	06-4361 (L) 06-4301 (R)	07-2925
NT647 Hawk	1.375", 1"	05-0320	-----	06-0300	07-0675
RC51	1", .5"	05-0340	-----	06-0300 (L) 06-0301 (R)	OEM
CBR1000RR 2004-07	1", .5"	-----	05-0337B	06-0360	07-28375
CBR1000RR 2008+	1", .5"	05-0339 w/shift	05-0339B	06-4301	07-2750

### Kawasaki

Model	Rise Up & Back	Rearset Kit	Full Kit w/pedals	Repl. Pegs	Shift Rod
EX250 1988+ BLK	1", 2"	05-4130	05-4130B	06-4610	07-0650
EX250 1988+ SLV	1", 2"	05-0130	05-0130B	06-0610	07-0650
EX500 1994+	1", 2"	05-0120	-----	06-0300	07-0675
Ninja 650R 2006+ BLK	Adjustable	05-4128 w/shift	05-4128B	06-4128 (L) 06-4301 (R)	07-1100
Ninja 650R 2006+ SLV	Adjustable	05-0128 w/shift	05-0128B	06-0128 (L) 06-0301 (R)	07-1100
ZX6R 1995-97	1", .5"	05-0100	-----	06-0110	07-0850
ZX6R 1998-02	1", 1"	05-0110	05-0110B	06-0112 (L) 06-0110 (R)	07-2775
ZZR600 2005-07	1", 1"	05-0110	05-0110B	06-0112 (L) 06-0110 (R)	07-2775
ZX6RR / 636 2003-04	.5", .5"	05-0140	05-0140B	06-0112 (L) 06-0110 (R)	07-2775
ZX6R / 636 2005-06	.5", .5"	05-0145	05-0145B	06-0801	07-2625
ZX6R 2007-08 BLK	Adjustable	05-0147	05-0147B	06-4801	07-2650
ZX6R 2009+	1", .5"	05-0149 w/brake	05-0149B	06-4801	07-2700
ZX7R 1991-04	1", .5"	05-0100	-----	06-0110	07-0850
ZX9R 1994-97	1", .5"	05-0100	-----	06-0110	07-0850
ZX9R 1998-04	1", 1"	05-0110	05-0110B	06-0112 (L) 06-0110 (R)	07-2775
ZX10R 2004-05	Adjustable	05-0160	05-0160B	06-0801	07-0775
ZX10R 2006+	Adjustable	05-0165	05-0165B	06-4801	07-2775

*"I appreciate that Woodcraft still continues to support my 21 year old Hawk..."*



by CFMotersports



Triumph

Model	Rise Up & Back	Rearset Kit	Full Kit w/pedals	Repl. Pegs	Shift Rod
675 STD BLK	Adjustable	-----	05-0500B	06-4801	07-0875
675 GP BLK	Adjustable	-----	05-0501B	06-4801	07-0575



### What is GP-shift?

**GP-shift** is the common term for reversing the shift pattern of your motorcycle. A bike equipped with GP-shift engages first gear by pulling up on the shift lever and is primarily done for racetrack applications.



A Triumph 675 & Yamaha R6 featuring the range of Woodcraft products. Rearsets, Frame Sliders, Case Covers, and Clip-Ons.

Yamaha

Model	Rise Up & Back	Rearset Kit	Full Kit w/pedals	Repl. Pegs	Shift Rod
FZR400 / 600	1", 1"	05-0410	-----	06-0410	07-0675
R6 1999-02 STD	.625", .625"	05-0440	05-0440B	06-0300 (L) 06-0420 (R)	07-0440
R6 1999-02 GP	.625", .625"	05-0442	05-0442B	06-0300 (L) 06-0420 (R)	07-0442
R6 2003-05	.625", .625"	05-0447	05-0447B	06-0300 (L) 06-0420 (R)	07-0445
R6 2006+ STD BLK	.625", .625"	05-0448 w/shift	05-0448B	06-4300 (L) 06-4420 (R)	07-2102
R6 2006+ GP BLK	.625", .625"	05-0449 w/shift	05-0449B	06-4300 (L) 06-4420 (R)	07-1062
R1 1998 STD	.875", .5"	05-0420	-----	06-0420	07-0420
R1 1998 GP	.875", .5"	05-0422	-----	06-0420	07-0422
R1 1999-01	.875", .5"	05-0420	-----	06-0420	07-0420
R1 2002-03 STD	.875", .5"	05-0424	-----	06-0420	07-0424
R1 2002-03 GP Conversion Kit		08-0424	Kit combines with 05-0424 to make GP kit		
R1 2004-06	1", .5"	05-0425	05-0425B	06-0425	07-0425
R1 2004-06 GP Conversion Kit		08-0427	Kit combines with 05-0425 to make GP kit		
R1 2007-08 STD BLK*	1", .5"	05-0428 w/shift	05-0428B	06-4425 (L) 06-4301 (R)	07-0425
R1 2007-08 GP BLK*	1", .5"	05-0429 w/shift	05-0429B	06-4425 (L) 06-4301 (R)	07-2115
R1 2009+	Adjustable	05-0452	05-0452B	06-4801	07-2725

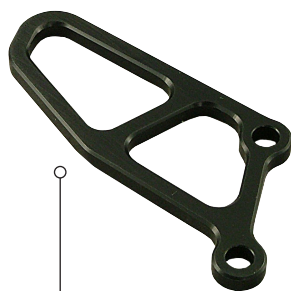

05-0428HGB

### Note-

Yamaha Rearset Kits marked (\*) can add an optional billet aluminum brake-side heel guard.

# Foot Controls

## Rearset Kits

by CFM Motorsports

**Suzuki**

Model	Rise Up & Back	Rearset Kit	Full Kit w/pedals	Repl. Pegs	Shift Rod
SV650 1999-02*	1.5", 1.5"	05-0220	05-0220B	06-0200	07-0775
SV650 1999-02 High*	2", 2"	05-0222	05-0222B	06-0200	07-0825
SV650S 1999-02*	.75", .75"	05-0220	05-0220B	06-0200	07-0775
SV650S 1999-02 High*	1.25", 1.25"	05-0222	05-0222B	06-0200	07-0825
SV650 2003*	1.25", 1.25"	05-0224	05-0224B	06-0200	07-0775
SV650s 2003*	.75", .75"	05-0224	05-0224B	06-0200	07-0775
SV650 2004+*	1.25", 1.25"	-----	05-0224B	06-0200	07-0775
SV650S 2004+*	.75", .75"	-----	05-0224B	06-0200	07-0775
SV650 2003 BLK*	1.25", 1.25"	05-4224	05-4224B	06-4200	07-0775
SV650s 2003 BLK*	.75", .75"	05-4224	05-4224B	06-4200	07-0775
SV650 2004+ BLK*	1.25", 1.25"	-----	05-4224B	06-4200	07-0775
SV650S 2004+ BLK*	.75", .75"	-----	05-4224B	06-4200	07-0775
SV1000 2003-07*	1.25", 1.25"	05-0226	05-0226B	06-0200	07-0825
SV1000S 2003-07*	.75", .75"	05-0226	05-0226B	06-0200	07-0825
GSX-R600 1997-00*	.75", .75"	05-0220	05-0220B	06-0200	07-0775
GSX-R600 2001-05*	.5", .5"	05-0240	05-0240B	06-0200	07-0750
GSX-R600 2006+ BLK*	Adjustable	05-0247 w/shift	05-0247B	06-4301 (L) 06-4245 (R)	OEM
GSX-R750 1996-99*	.75", .75"	05-0220	05-0220B	06-0200	07-0775
GSX-R750 2000-05*	.5", .5"	05-0240	05-0240B	06-0200	07-0750
GSX-R750 2006+ BLK*	Adjustable	05-0247 w/shift	05-0247B	06-4301 (L) 06-4245 (R)	OEM
GSX-R1000 2001-04*	.5", .5"	05-0240	05-0240B	06-0200	07-0750
GSX-R1000 2005-06*	.5", .5"	05-0245	05-0245B	06-0245	07-0160
GSX-R1000 2007-08 BLK*	Adjustable	05-0249	05-0249B	06-4245	07-0725
GSX-R1000 2009+	Adjustable	05-0250 w/shift	05-0250B	06-4301 (L) 06-4245 (R)	OEM
TL1000S	.75", .75"	05-0210	05-0210B	06-0200	07-0850
TL1000R	.75", .75"	05-0212	05-0212B	06-0200	07-0750



05-0249HGB

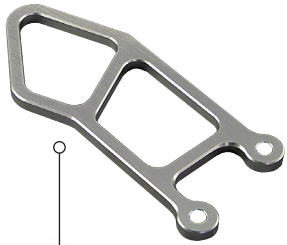

05-0240HG

**Note-**  
Suzuki Rearset Kits marked (\*) can add an optional billet aluminum brake-side heel guard.

## Brake Switches & Pedal Springs

### Brake Light Switches

These kits make it possible to retain the rear brake light function when using our Woodcraft Rearset Kits. The switch is pressure activated and replaces the banjo bolt that connects the rear brake line to the rear master cylinder. **Please call if you are unsure of your bike's thread-type and we'll gladly assist you. 978-297-2977**

### Pedal Return Springs

Some riders prefer a positive feel of a return spring when using their rear brake. For them we offer our Pedal Return Spring Kits which can be fitted to many of our Rearset Kits. **We're adding new models constantly so please call if your bike isn't listed. 978-297-2977**



Brake Light Switch



Return Spring Kit

Pedal Return Spring Kits	Part Number
Yamaha R1, R6 (fits most)	09-7125
Suzuki (fits most models)	09-7175

Call for additional applications 978-297-2977

Brake Light Switch	Part Number
Coarse Thread Switch	03-0100
Fine Thread Switch	03-0105

*All individual kit pieces are available separately!*



### Toughness

CFMotersports pedals are CNC machined from 6061-T6 billet aluminum and are 3-4 times stronger than most OEM pedals. They can bend to nearly 90 degrees before breaking!

### Economical

Our 3-piece design allows you to replace parts separately making repairs easy and costing less than OEM replacements.

### Shifting Improvement

Stiffer components, higher tolerances, and an optional short throw hole (on most models) means a more positive action and improved shifting!

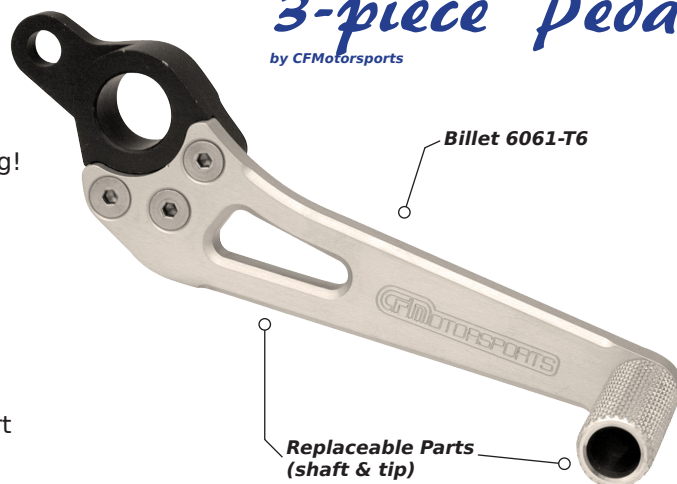

Legend
GP = GP shift only
STD = Standard shift only
No Mark = Can do GP & STD
BLK = Black
SLV = Silver
* = Eccentric Pedal Tip

Model	Pedals fit OEM brackets?	Shift Pedal	Repl. Shift Shaft	Brake Pedal	Shorty Brake Pedal	Repl. Brake Shaft
RS125 2006+	Brake only	08-0731	08-1145*	09-0730	-----	09-1330
RS250 Cup	No	08-0700	08-2099	09-0700	09-0700S	09-1099
Mille/R GP	No	08-0712	08-1199	-----	-----	-----
RSV / Tuono	No	08-0722	08-1199	-----	-----	-----
RSV4			TBA			

Model	Pedals fit OEM brackets?	Shift Pedal	Repl. Shift Shaft	Brake Pedal	Shorty Brake Pedal	Repl. Brake Shaft
S1000RR GP	No	08-0751	08-4145*	09-0750	-----	09-4330
S1000RR STD	No	08-0750	08-4145*	09-0750	-----	09-4330

Model	Pedals fit OEM brackets?	Shift Pedal	Repl. Shift Shaft	Brake Pedal	Shorty Brake Pedal	Repl. Brake Shaft
XB9 / XB12 STD	No	08-0800	08-1800*	09-0800	-----	09-1099
XB9 / XB12 GP	No	08-0805	08-1805	09-0800	-----	09-1099
1125			TBA			

Model	Pedals fit OEM brackets?	Shift Pedal	Repl. Shift Shaft	Brake Pedal	Shorty Brake Pedal	Repl. Brake Shaft
Monster 696 / 1100	No	08-0660	08-4145*	09-0660	-----	08-4660*
750 / 900SS 1991-98	Yes	08-0600	08-1199	09-0600	09-0600S	09-1099
750/800/900/1000 99-07	Yes	08-0620	08-1620*	09-0620	-----	09-1620
748/916/996/998	Brake only	08-0610	08-1199	09-0620	-----	09-1620
848/1098/1198 BLK	Brake only	08-0640	08-4620*	09-0640	-----	09-4620
848/1098/1198 SLV	Brake only	08-0640A	08-1620*	09-0640A	-----	09-1620
Hypermotard	No	08-0650	08-4145*	09-0650	-----	08-4247*

Model	Pedals fit OEM brackets?	Shift Pedal	Repl. Shift Shaft	Brake Pedal	Shorty Brake Pedal	Repl. Brake Shaft
CBR600 F4 1999-00	Yes	08-0330	08-1199	09-0330	-----	09-1330
CBR600 F4i 2000-06	Yes	08-0330	08-1199	09-0332	-----	09-1330
CBR600RR 2003-06	No	08-0335	08-1335	09-0335	09-0335S	09-1099
CBR600RR 2007+	No	08-0338	08-4335	09-0338	09-0338S	09-4330
CBR1000RR 2004-07	No	08-0335	08-1335	09-0335	09-0335S	09-1099
CBR1000RR 2008+	No	08-0339	08-4145*	09-0339	09-0339S	09-4330



\* = Eccentric pedal tip

All individual kit pieces are available separately!

# Foot Controls

## 3-piece Pedals

by CFMotersports

**Kawasaki**

Model	Pedals fit OEM brackets?	Shift Pedal	Repl. Shift Shaft	Brake Pedal	Shorty Brake Pedal	Repl. Brake Shaft
EX250 1988+ SLV	No	08-0130	08-2099	09-0128	-----	09-1330
EX250 1988+ BLK	No	08-4130	08-4099	09-4128	-----	09-4330
ZX6R/RR/636 1998-04	No	08-0110	08-2099	09-0110	09-0110S	09-1099
ZX6R/636 2005-06	Yes	08-0145	08-1145*	09-0145	-----	09-1330
ZX6R/636 2007-08	Yes	08-0147	08-4145*	09-0147	-----	09-4330
ZX6R 2009+	No	08-0147	08-4145*	09-0149	-----	08-4247*
650R 2006+ SLV	No	08-0128	08-2099	09-0128	-----	09-1330
650R 2006+ BLK	No	08-4128	08-4099	09-4128	-----	09-4330
ZX9R 1998-03	No	08-0110	08-2099	09-0110	09-0110S	09-1099
ZX10R 2004-05	Yes	08-0160	08-1335	09-0160	-----	09-1330
ZX10 2006+	Yes	08-0165	08-4145*	09-0165	-----	09-4330



**BLK Eccentric Repl. Tip**  
08-4899

**Triumph**

Model	Pedals fit OEM brackets?	Shift Pedal	Repl. Shift Shaft	Brake Pedal	Shorty Brake Pedal	Repl. Brake Shaft
675 2006+ STD	No	08-0500	08-4145*	09-0500	-----	09-4330
675 2006+ GP	No	08-0501	08-4145*	09-0500	-----	09-4330



**Eccentric Repl. Tip**  
08-0899

**Suzuki**

Model	Pedals fit OEM brackets?	Shift Pedal	Repl. Shift Shaft	Brake Pedal	Shorty Brake Pedal	Repl. Brake Shaft
SV650/S 1999+ SLV	Yes (99-03)	08-0200	08-2099	09-0200	09-0200S	09-1099
SV650/S 2003+ BLK	Yes (03 only)	08-4200	08-4199	09-4200	09-4200S	09-4099
SV1000/S 2003+	Yes (03 only)	08-0200	08-2099	09-0200	09-0200S	09-1099
TL1000R/S 1997+	Yes	08-0200	08-2099	09-0200	09-0200S	09-1099
GSX-R600 1997-00	Yes	08-0200	08-2099	09-0200	09-0200S	09-1099
GSX-R600 2001-05	Yes	08-0200	08-2099	09-0240	09-0240S	09-1099
GSX-R600 2006+	Yes	08-0247	08-4247*	09-0247	09-0247S	09-4099
GSX-R750 1996-99	Yes	08-0200	08-2099	09-0200	09-0200S	09-1099
GSX-R750 2000-05	Yes	08-0200	08-2099	09-0240	09-0240S	09-1099
GSX-R750 2006+	Yes	08-0247	08-4247*	09-0247	09-0247S	09-4099
GSX-R1000 2001-04	Yes	08-0200	08-2099	09-0240	09-0240S	09-1099
GSX-R1000 2005-06	No	08-0245	08-2099	09-0245	09-0245S	09-1099
GSX-R1000 2007-08	No	08-0249	08-4199	09-0249	09-0249S	09-4099
GSX-R1000 2009+	Shift only	08-0247	08-4247*	09-0249	09-0249S	09-4099



**BLK Standard Repl. Tip**  
08-4099

**Yamaha**

Model	Pedals fit OEM brackets?	Shift Pedal	Repl. Shift Shaft	Brake Pedal	Shorty Brake Pedal	Repl. Brake Shaft
R6 1999-02	Yes	08-0440	08-1440	09-0440	09-0440S	09-1099
R6 2003-05	Yes	08-0440	08-1440	09-0445	09-0445S	09-1099
R6 2006+ STD	Yes	08-0448	08-1449	09-0449	09-0449S	09-4099
R6 2006+ GP	Yes	08-0449	08-1449	09-0449	09-0449S	09-4099
R1 2004-06	Yes	08-0425	08-1335	09-0445	09-0445S	09-1099
R1 2007-08 STD	Brake only	08-0428	08-4335	09-0428	-----	09-4330
R1 2007-08 GP	Brake only	08-0429	08-4335	09-0428	-----	09-4330
R1 2009+	Yes	08-0452	08-4247*	09-0452	-----	09-4099



**Standard Repl. Tip**  
08-0099

**Note-**  
These pedals are designed for racing use only! Street use requires a brake light switch (see page 9) & may require custom fabrication to fit a return spring (see page 9)

\* = Eccentric pedal tip

*I really like the multiple pieces..easy to fix!* - David Lane



Woodcraft Case Covers are designed to add strength, protect your motorcycle and look great. These covers are meticulously produced in the USA out of the very best materials available. These covers help ensure that when your bike hits the ground the vital fluids stay inside the motor and the gravel will stay out, allowing you to get back to riding as soon as possible.

## Replaceable Skid Pads

Woodcraft Case Covers feature replaceable skid pads in both stainless steel (for racing durability & ground clearance) or Double Thick Aluminum (street looks with extra thick protection).

## Internally Bolted

**A Woodcraft exclusive!** These O-ring sealed bolts make sure that a spill will not leave you drilling out mounting bolts that were ground smooth in the crash.

## Attention to Detail

These covers get the extra attention needed to make them **lightweight and great looking**. A head-turning addition for both street and race bikes!

## Customizable

**Any cover can be ordered with any skid pad**, meaning you can customize the cover to suit your bike. Black covers with red pads? Aluminum with black? Be creative and make your bike an original!

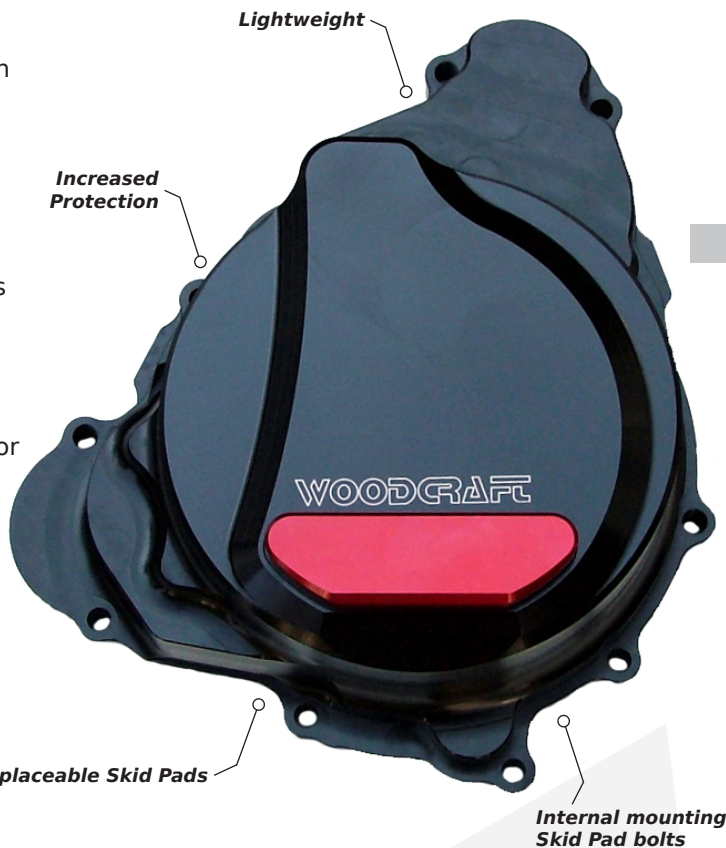

## Skid Pads

All of our Case Covers come with either a stainless steel or aluminum skid pad (default is stainless). You have the option to choose whatever Skid Plate you'd like in both material and color!

Skid Pad	Color Code Suffix
Original Stainless*	S
Natural Aluminum	A
Black Aluminum	B
Blue Aluminum	C
Red Aluminum	R
Example	60-0220RA
* = best clearance for track applications	



### Notes-

#### > Important Ordering Instructions:

- 1) Choose your Cover (black anodized is standard, some models offered in Silver)
- 2) Select your Skid Pad & add suffix to Part Number (see Skid Pads below)

- > If you do not select a Skid Pad a stainless pad will be sent by default.
- > All covers include the gasket (if needed) & Skid Pad (SS or Aluminum) at no extra cost!



60-0245LB



60-0145R



60-0449LB

Legend	
CL	= Clutch Cover
CP	= Crank Cover Protector
CLP	= Clutch Cover Protector
IG	= Starter Idle Gear Cover
IT	= Ignition Trigger Cover
OP	= Oil Pump Cover
S	= Stator Cover

## Aprilia

Model	Cover Side	Type	Clear Anodized	Black Anodized	Gasket	Skid Pad Stainless	Skid Pad Aluminum
RSV4	Left	CP	-----	60-0725LB	None	TBA	TBA
	Right	CLP	-----	60-0725RB	None	TBA	TBA



60-0640L

## Ducati

Model	Cover Side	Type	Clear Anodized	Black Anodized	Gasket	Skid Pad Stainless	Skid Pad Aluminum
748-999	Right	CL	-----	60-0640RB	None	65-0247S	65-0247 + suffix
1098 / 1198	Right	CL	-----	60-0640RB	None	65-0247S	65-0247 + suffix
Supersport / Sportclassic	Right	CL	-----	60-0640RB	None	65-0247S	65-0247 + suffix
Multistrada / Hypermotard	Right	CL	-----	60-0640RB	None	65-0247S	65-0247 + suffix

## Honda

Model	Cover Side	Type	Clear Anodized	Black Anodized	Gasket	Skid Pad Stainless	Skid Pad Aluminum
CBR600RR 2003-06	Left	S	-----	60-0335LB	None	65-0240S	65-0240 + suffix
	Right	CLP	-----	60-0335RB	None	65-0335S	65-0335 + suffix
CBR600RR 2007+	Left	S	-----	60-0338LB	None	65-0160S	65-0160 + suffix
	Right	CLP	-----	60-0338RB	None	65-0335S	65-0335 + suffix
CBR1000RR 2004-07	Left	S	-----	60-0337LB	None	65-0160S	65-0160 + suffix
	Right	CLP	-----	60-0337RB	None	65-0160S	65-0160 + suffix
CBR1000RR 2008+	Left	S	-----	60-0339LB	None	65-0160S	65-0160 + suffix
	Right	CLP	-----	60-0339RB	None	TBA	TBA

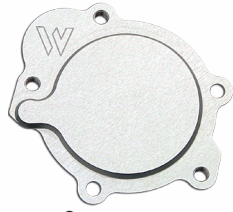

60-0165R

## Kawasaki

Model	Cover Side	Type	Clear Anodized	Black Anodized	Gasket	Skid Pad Stainless	Skid Pad Aluminum
ZX6RR / 636 2003-04	Left	S	-----	60-0140LB	61-0140L	65-0240S	65-0240 + suffix
	Right	IT	60-0145R	60-0145RB	61-0145R	65-0160S	65-0160 + suffix
ZX6RR / 636 2005-06	Left	S	60-0145L	60-0145LB	61-0145L	65-0240S	65-0240 + suffix
	Right	IT	60-0145R	60-0145RB	61-0145R	65-0160S	65-0160 + suffix
ZX6R 2007-08	Left	S	-----	60-0147LB	61-0147L	65-0160S	65-0160 + suffix
	Right	IG	-----	60-0147ROB	61-0147RO	None	None
	Right	CP	-----	60-0147RIB	None	65-0335S	65-0335 + suffix
ZX10R 2004-05	Left	IG	-----	60-0160LOB	61-0160LO	None	None
	Left In	CR	-----	60-0160LIB	61-0160LI	65-0160S	65-0160 + suffix
ZX10R 2006+	Left	S	-----	60-0165LB	61-0165L	65-0440S	65-0440 + suffix
	Right	IG	-----	60-0165RB	61-0165R	None	None



60-0147ROB

*"I crashed & my bike slide for more than 300'..the cover held up so well..."*



Triumph

Model	Cover Side	Type	Clear Anodized	Black Anodized	Gasket	Skid Pad Stainless	Skid Pad Aluminum
675 2006+	Left	S	-----	60-0500LB	61-0500L	60-0160S	60-0160 + suffix
	Right	IT	-----	60-0500RB	61-0500R	65-0440S	65-0440 + suffix

Suzuki

Model	Cover Side	Type	Clear Anodized	Black Anodized	Gasket	Skid Pad Stainless	Skid Pad Aluminum
SV650 / S 1999-02	Right	CL	60-0220R	60-0220RB	None	65-0440S	65-0440 + suffix
SV650 / S 2003+	Right			TBA			
GSX-R600 2001-03	Left	S	60-0240L	60-0240LB	61-0240L	65-0240S	65-0240 + suffix
GSX-R600 1997-05	Right	IG	60-0240R	60-0240RB	61-0240R	None	None
	Right	CP	-----	60-0249RIB	None	65-0249S	65-0249 + suffix
GSX-R600 2004-05	Left	S	60-0242L	60-0242LB	61-0242L	65-0240S	65-0240 + suffix
GSX-R600 2006+	Left In	S	-----	60-0247LIB	61-0247LI	65-0160S	65-0160 + suffix
	Left Out	IG	-----	60-0247LOB	61-0247LO	None	None
	Right	CLP	60-0247R	60-0247RB	None	65-0247S	65-0247 + suffix
GSX-R750 2000-03	Left	S	60-0240L	60-0240LB	61-0240L	65-0240S	65-0240 + suffix
GSX-R750 1996-05	Right	IG	60-0240R	60-0240RB	61-0240R	None	None
	Right	CP	-----	60-0249RIB	None	65-0249S	65-0249 + suffix
GSX-R750 2004-05	Left	S	60-0242L	60-0242LB	61-0242L	65-0240S	65-0240 + suffix
GSX-R750 2006+	Left In	S	-----	60-0247LIB	61-0247LI	65-0160S	65-0160 + suffix
	Left Out	IG	-----	60-0247LOB	61-0247LO	None	None
	Right	CLP	60-0247R	60-0247RB	None	65-0247S	65-0247 + suffix
GSX-R1000 2001-02	Left	S	60-0240L	60-0240LB	61-0240L	65-0240S	65-0240 + suffix
GSX-R1000 2001-07	Right	IG	60-0240R	60-0240RB	61-0240R	None	None
GSX-R1000 2001-08	Right	CP	-----	60-0249RIB	None	65-0249S	65-0249 + suffix
GSX-R1000 2003-04	Left	S	60-0242L	60-0242LB	61-0242L	65-0240S	65-0240 + suffix
GSX-R1000 2005-08	Left	S	60-0245L	60-0245LB	61-0242L	65-0240S	65-0240 + suffix
GSX-R1000 2009+	Left	S	-----	60-0250LB	61-0250L	65-0160S	65-0160 + suffix
	Right	CLP	-----	60-0250RB	None	65-0249S	65-0249 + suffix
Hayabusa	Left	S	60-0270LBD	60-0270LB	61-0270L	65-0440S	65-0440 + suffix



60-0249RIB



60-0247RB



60-0449RB



60-0449LB

Yamaha

Model	Cover Side	Type	Clear Anodized	Black Anodized	Gasket	Skid Pad Stainless	Skid Pad Aluminum
R6 2003-05	Left	S	-----	60-0445LB	61-0445L	65-0160S	65-0160 + suffix
	Right	IT	-----	60-0445RB	61-0440R	65-0240S	65-0240 + suffix
R6S 2006+	Left	S	-----	60-0445LB	61-0445L	65-0160S	65-0160 + suffix
	Right	IT	-----	60-0445RB	61-0440R	65-0240S	65-0240 + suffix
R6 2006+	Left	S	-----	60-0449LB	61-0449L	65-0440S	65-0440 + suffix
	Right	IT	-----	60-0449RB	61-0449R	65-0337S	65-0337 + suffix
R1 1998-03	Left	S	-----	60-0420LB	61-0420L	65-0160S	65-0160 + suffix
	Right	IT	-----	60-0420RB	61-0420R	65-0160S	65-0160 + suffix
R1 2004-08	Left	ICP	-----	60-0450LB	None	65-0335S	65-0335 + suffix
	Right	OP	-----	60-0450RB	61-0450R	65-0440S	65-0440 + suffix
R1 2009+	Left	S	-----	60-0452LB	61-0452L	65-0160S	65-0160 + suffix
	Right	IT	-----	60-0452RB	61-0452R	65-0337S	65-0337 + suffix

...I haven't even replaced the slid plate..definitely \$\$\$ well spent!" - Mike Simmons

Frame Sliders are one of the smartest investments you can make to your bike. From roadway accidents to 100mph high-sides nothing will help prevent costly damage more than a set of Woodcraft Frame Sliders. Our Sliders are the only sliders on the market featuring our patented perpendicular mounting bolt design giving you a solid slider, great protection and an easy install.

## Durability

Woodcraft's **patented** 2-piece sliders are the most durable sliders on the market. Our perpendicular mounting bolt allows the slider to be solid rather than hollow (like other sliders) which **provides nearly 50% more material on the road and much greater durability.**

## Hassle Free Replacement

Our 2-piece design with its perpendicular mounting bolt means that after a crash you won't be digging out a ground down bolt from the center of a destroyed hollow slider. Our sliders make puck replacement fast and easy thanks to our **patented** design.

## Race Proven

Woodcraft's experienced racer R&D squad made it clear that sliders must stick out far enough to protect the bike but not so long they get ripped off as the bike slides down the road! The end result is all Woodcraft sliders are the **ideal length** giving you the protection without too much projection.



Aprilia

Model	Slider Base Kit	Cut OEM bodywork?	Repl. plastic puck
RSV/R 2004+	50-0720	Yes	50-1099
Tuono 2006+	50-0720	No	50-1099
RSV4	50-0725	TBA	TBA

BMW

Model	Slider Base Kit	Cut OEM bodywork?	Repl. plastic puck
S1000RR	50-0750	TBA	TBA

Ducati

Model	Slider Base Kit	Cut OEM bodywork?	Repl. plastic puck
Monster 696 / 1100	50-0660	TBA	TBA
848 / 1098 / 1198	50-0640	Yes	50-1099

Honda

Model	Slider Base Kit	Cut OEM bodywork?	Repl. plastic puck
CBR600F4/F4i 1999-02	50-0330	Yes	50-1099
CBR600RR 2003-06	50-0335	Yes	50-1199
CBR600RR 2007+	50-0338	Yes	50-1199
CBR1000RR 2004-07	50-0337	Yes	50-1099
CBR1000RR 2008+	50-0339	Yes	50-1199

Puck Style	Part Number
High Density Plastic (Std)	50-1099
Blue Anodized Aluminum	50-1099C
Chrome Plated Aluminum	50-1099K
Red Anodized Aluminum	50-1099R
CBR Short Plastic	50-1199
Short High Density Plastic	50-1399



### Notes-

#### > Important Ordering Instructions:

- 1) Order the Slider Base Kit for your model bike
- 2) Order two (2) Slider Pucks to complete your Kit

> All Kits can use the aluminum pucks except Kits using the **50-1199** pucks.

> Woodcraft recommends the slightly shorter 50-1399 high-density plastic pucks for many track applications.

*"Being in the frame alignment business, we see a lot of frame sliders that do more damage than they prevent. Woodcraft Frame Sliders are designed to protect the frame without causing unnecessary damage to the mounting points. We won't sell any other brand."* - Peter Kates GMD Computrack Boston



**Kawasaki**

Model	Slider Base Kit	Cut OEM bodywork?	Repl. plastic puck
600RR / 636 2003-04	50-0140	Yes	50-1099
600RR / 636 2005-06	50-0145	Yes	50-1099
ZX6R 2007-08	50-0147	Yes	50-1399
ZX6R 2009+	50-0149	Left only	50-1399
Ninja 650R 06-08	50-0128	Yes	50-1099
Ninja 650R 2009+	50-0129	Yes	50-1099
ZX10R 2004-05	50-0160	Yes	50-1099
ZX10R 2006-07	50-0165	Yes	50-1399
ZX10R 2008+	50-0167	Yes	50-1399

**Yamaha**

Model	Slider Base Kit	Cut OEM bodywork?	Repl. plastic puck
R6 1999-02	50-0440	Yes	50-1099
R6 2003-05	50-0445	Yes	50-1099
R6S 2006-08	50-0446	Yes	50-1099
R6 2006-07	50-0449	Yes	50-1099
R6 2008+	50-0449	Yes	50-1399
R1	50-0425	Yes	50-1099
FZ1	50-0415	No	50-1099
FZ6	50-0443	No	50-1099

**Suzuki**

Model	Slider Base Kit	Cut OEM bodywork?	Repl. plastic puck
SV650/S 1999-02	50-0220	No	50-1099
SV650/S 2003+	50-0224	No	50-1099
SV1000/S	50-0226	No	50-1099
GSX-R600 1997-00	50-0200	Yes	50-1099
GSX-R600 2001-03	50-0240	Left only	50-1099
GSX-R600 2004-05	50-0240	No	50-1099
GSX-R600 2006-07	50-0247	Yes	50-1399
GSX-R600 2008+	50-0248	Yes	50-1399
GSX-R750 1996-99	50-0200	Yes	50-1099
GSX-R750 2000-03	50-0240	Left only	50-1099
GSX-R750 2004-05	50-0240	No	50-1099
GSX-R750 2006-07	50-0247	Yes	50-1399
GSX-R750 2008+	50-0248	Yes	50-1399
GSX-R1000 2003-06	50-0240	Left only	50-1099
GSX-R1000 2007-08	50-0249	No	50-1099
GSX-R1000 2009+	50-0250	No	50-1399

**Triumph**

Model	Slider Base Kit	Cut OEM bodywork?	Repl. plastic puck
675	50-0500	Yes	50-1099

Chuck Boucher



*"I lousided my SV650 at a trackday & sustained minimal damage, thanks to my Woodcraft frame sliders, spool sliders, rearsets, and clip-ons. Everything performed perfectly and individual component replacement parts meant minimal cost to repair."* - Chuck Boucher

Made from tough aircraft-grade aluminum and finished with a clear or black anodized finish our Woodcraft Shark Guards are a slick addition to any motorcycle.

## Inexpensive Insurance

Our Shark Guards are **cheap insurance against potential serious injury**. In many crashes your leg has a tendency to dangle near the rear sprocket. The Shark Guard's role is to help deflect your foot out of harm's way.

## Racing Required

Shark Guards are **required by top racing organizations** around the world including, but not limited to, the AMA Pro Racing series and the World Superbike series. No matter if this item is required by your local club or not, we feel it's a smart item to install.

## Easy of Installation

Other guards ask you to drill and tap holes into your stock swingarm. The average swingarm today is only 4-6mm thick aluminum which can leave you with mounting holes that easily strip out. **Only Woodcraft** supplies two rivet nut inserts and an installation tool with every kit!



Shark Guard	Part Number
Shark Guard Kit silver	55-0100
Shark Guard Kit black	55-4100
Replacement Mounting Kit	55-9000

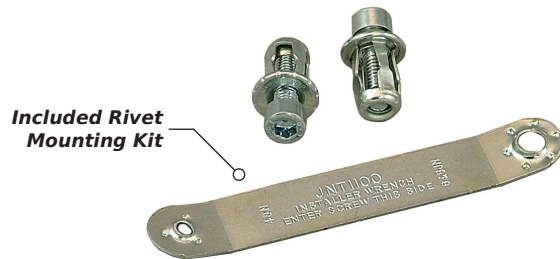

Jeff Wood AMA #19



Tire Warmers are an integral part of any motorcycle that plans on riding the track. We know the last thing you want to be worrying about before Pitting Out is if your tires are up to temp or not. We set out to build the best tire warmers on the market loaded with features that make tire warmer use a simple and safe experience, leaving you to focus on having fun and riding hard!

## Quick-Disconnect

When we were talking to our racers about warmer use we couldn't find one person who hadn't seen a warmer damaged when it was accidentally left plugged in. As a result, **Woodcraft brings another innovation to the table with the first safety disconnect cord ever used on a warmer.** Power to the warmer is cut the moment you remove it, saving you from expensive and unsafe 'accidents'!

## Power Efficient

Woodcraft's signature engineering allows our warmers to run on only 1,000 watts (20% less than the competition) while still supplying maximum heat. When power gets low the Woodcraft warmers will get you heat when the others fail.

## Heat Retaining Curtains

Months of testing have shown us that heat loss at the edge of the tire is the greatest factor when it comes to retaining heat from the warmer. As a result Woodcraft has solved this with our **new elasticized insulating fleece side curtains** which not only dramatically **cut heat loss but also saw a 10 degree gain in rim temperature!**



Josh Hayes & the Westby Racing R6 moments before winning the 2009 AMA Daytona 8-Hour



**Detail-**  
Push Button Digital Box (top)  
Dual Temp Switch (bottom)

## Push Button Digital

Our Push Button Digital warmers are our top-line offering and features our push-button digital temperature control box. With settings of 120, 140, 160, and 180 and the ability to display the current tire temp real time, this warmer keeps you informed and your tires hot.

## Dual Temp

With its heavy-duty selection switch (Warm 130-140 degrees or Hot 170-180 degrees, quick-disconnect cord, fleece side curtains, and LED power light, the Dual Temp warmers gives you a lower price-point while still packing all the signature Woodcraft tire warmer innovations.

Tire Warmers	Part Number
Push Button Digital	30-2500
Dual Temp	30-2100
Replacement Duffel Carry Bag	31-2500



### Notes-

> All Tire Warmer purchases include a free Woodcraft duffel carrying case (see p.29)

*I love my warmers... I just watched my buddy burn through another brand when he left them plugged in. Your design has saved me 2x!* - Chris Ormonde CCS #617



## Solo Operation Front Stand

All stands are the same right? Not exactly. We interviewed top mechanics and asked them what they feel are the most important features in a stand. The overwhelming responses were: **low lift effort, clearance for working, and wheel design** (for ease of rolling and stability). We incorporated these features into our full-range of Woodcraft Wheel Stands, **all proudly built in the USA.**

### Low Lift Effort

A stand is your most frequently used tool. Woodcraft stands are engineered to ensure our stands lift with low physical effort **without sacrificing stability or work space.**

### Stability

Woodcraft stands provide the highest standard in the Industry for our stand wheels. The quad 4" wheels are unmatched for both stability and their ability to roll smoothly over rough surfaces.

### Guaranteed for Life

Top quality craftsmanship allows Woodcraft to guarantee all of our stands against defects in material or workmanship. We feel that our stand is a tool that should last a lifetime and **we guarantee it.**

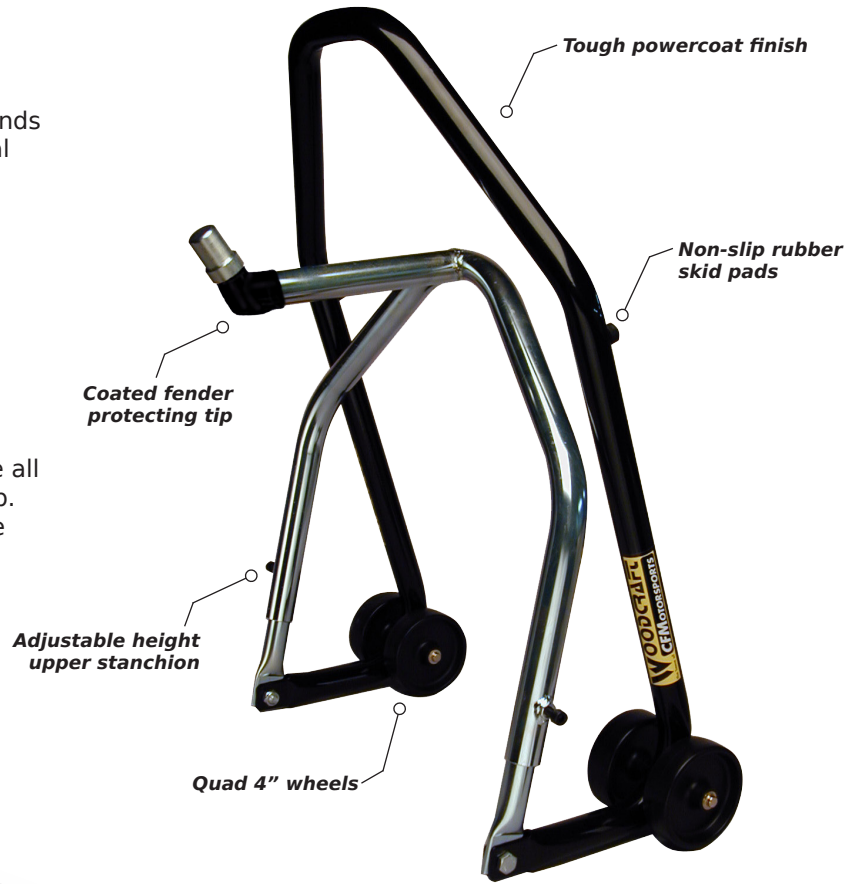

Stand	Part Number
Front Stand	22-0100
Pin	Part Number
13mm FS101 pin	23-0113
15mm FS101 pin	23-0115
16.5mm FS101 pin	23-01165
17mm FS101 pin	20-0117
18mm FS101 pin	23-0118
19mm FS101 pin	23-0119
20mm FS101 pin	23-0120
21mm FS101 pin	23-0121
23mm FS101 pin	23-0123
24mm FS101 pin	23-0124
27mm FS101 pin	23-0127



### Coated Tip

Save that fender! Our coated stand tip keeps your front fender safe.

### Security

Another Woodcraft touch: Non-slip rubber skid pads on the bottom of our front stands makes sure the stand, and your bike, stays put.

### Adjustability

Our front stands feature an adjustable upper stanchion meaning you can use your front stand from an RS125 to a GSX-R1000.

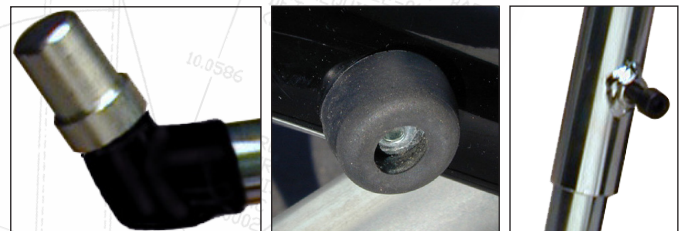

*"My 12 year old daughter has no problem putting my SUV on this stand...perfect."* - Ted Temple

## Front Stand pin application chart

Aprilia	Size	Honda (continued)	Size	Suzuki	19Size
RS250	16.5	CBR600RR 2007+	13	GSX-R600 1997-05	13
Mille / R	27	NT647 Hawk	24	GSX-R600 2006+	15
Falco / Tuono	27	VFR750 / 800	24	GSX-R750 1991-95	24
Tuono Factory 2007+	19	CBR900RR 1993-97	24	GSX-R750 1996-05	13
Factory / R	19	CBR900RR 1998-99	13	GSX-R750 2006+	15
RSVR	19	CBR929 / 954	13	GSX-R1000 2001-02	13
<b>Attack Clamps</b>	<b>20</b>	RC51 to 2001	13	GSX-R1000 2003-04	17
<b>BMW</b>		RC51 2002+	27	GSX-R1000 2005+	13
S1000RR		CBR1000RR to 2007	13	GSX-R1100	24
K5 / K100	21	CBR1000RR 2008+	23	RF600 / 900	24
<b>Buell</b>		ST1100	21	SV650 / S 1999-02	21
Blast / Cyclone	18	CBR1100XX	24	SV650 / S 2003+	16.5
S1 / S2 / Lightning	18	<b>Kawasaki</b>		V-Strom	17
XB9 / XB12	18	EX250 to 2007	19	TL1000S / R*	13
1125R	18	EX250 2008+	18	Hayabusa*	13
<b>Ducati</b>		EX500 1987-93	19	SV1000 / S 2003	13
620 - 1000SS	17	EX500 1994+	20	SV1000 / S 2004+	20
Monster 696	27	ZX6E 1993+	21	<b>Triumph</b>	
Hypermotard	27	ZX6R 1995-02	13	Speed Triple / T509 / 595	19
Monster to 2002	17	ZX6RR / 636 2003+	15	Daytona 955i	19
Monster 2003+	27	Ninja 650R	27	TT600 / 675	13
Multistrada to 2009	24	ZX7R 1991+	27	<b>Yamaha</b>	
748 / 749 Base model	27	ZX9R 1994-97	27	TZ250	13
749R	13	ZX9R 1998+	15	RZ350 / 500	19
748/749/916/996/998/999	N/A	Z1000	27	FZR400 / 600 / 1000	21
848	27	ZX10R 2004-07	15	Seca II	19
1098 / 1198	N/A	ZX10R 2008+	27	R6S 2006-07	21
<b>Honda</b>		ZXR1100	17	R6 2001+	16.5
RS125 to 1994	15	ZX11 to 1992	20	YZF600 to 1996	19
RS125 1995+	13	ZX11 1993+	27	YZF600 1997-00	21
RS250	24	ZX12 to 2001	13	YZF600 2001+	16.5
CB1	24	ZX12 2002+	17	YZF750	20
CBR600F / F2 / F3	24	<b>Suzuki</b>		R1	16.5
CBR600F4 / F4i	24	GS500	24	FZ1	19
CBR600RR 2003-06	20	GSX-R600 1994-96	24	FJ1200	19



### Reminder-

> Don't forget our front stand pins are quick and easy to remove. Have multiple bikes? Get multiple quick change lift pins to use with your Woodcraft Front Stand!

\* = requires front fairing removal for stand use

*"They work perfect for everything from wheel swaps to complete tear downs"* - Peter Kates GMD Computrack

# Wheel Stands

## Rear Stands

All stands are the same right? Not exactly. We interviewed top mechanics and asked them what they feel are the most important features in a stand. The overwhelming responses were: **low lift effort, clearance for working, and wheel design** (for ease of rolling and stability). We incorporated these features into our full-range of Woodcraft Wheel Stands, **all proudly built in the USA.**

### Low Lift Effort

A stand is your most frequently used tool. Woodcraft stands are engineered to ensure our stands lift with low physical effort **without sacrificing stability or work space.**

### Stability

Woodcraft stands provide the highest standard in the industry for our stand wheels. The quad 4" wheels are unmatched for both stability and their ability to roll smoothly over rough surfaces.

### Guaranteed for Life

Top quality craftsmanship allows Woodcraft to guarantee all of our stands against defects in material or workmanship. We feel that our stand is a tool that should last a lifetime and **we guarantee it.**



### Race Stand

Our Race Stand (pictured above) is for use with bikes equipped with swingarm spools (page 22) and features a wide-mouth deep-V receiver that is easy to line up and secure upon lifting.

### Pad Stand

For bike that aren't equipped with swingarm spools we offer up our Pad Stand. Outfitted with 1" diameter solid steel lift pivots that roll easily and won't bend or break like other stands. Our pivots have super tacky rubber pads to prevent slippage and Teflon-coated bushing to keep the stand operating smoothly. The Pad Stand is fully-adjustable from 11-14".

Rear Stands	Part Number
Race Stand	25-0100
Pad Stand	25-0200



*We do customer service! Have a question? Give us a ring 978-297-2977*



## Small Parts - Big Difference

Sometimes it's the little things that make all the difference. Woodcraft Swingarm Spools have wide grooves that make locating the stand easier and raised lips on either side that give them unparalleled stability.

## Race Protection

For racing applications the Woodcraft Swingarm Slider of choice is our solid Delrin model. The polyoxymethylene plastic offers extra protection in the case of an unfortunate crash and incorporates the secure raised edges our spools are known for.

## Street Finish

Our Swingarm Spools also are available in a trick hard anodized aluminum finish for that factory-look. Four color choices are available to suit your bikes colorways.

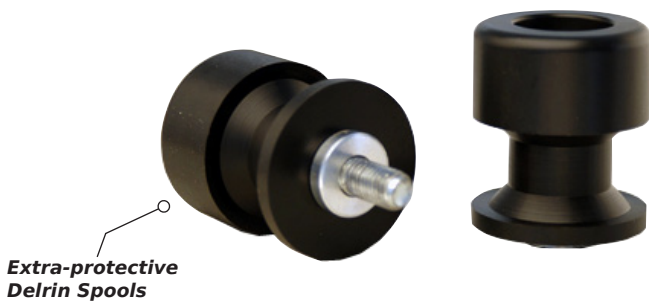
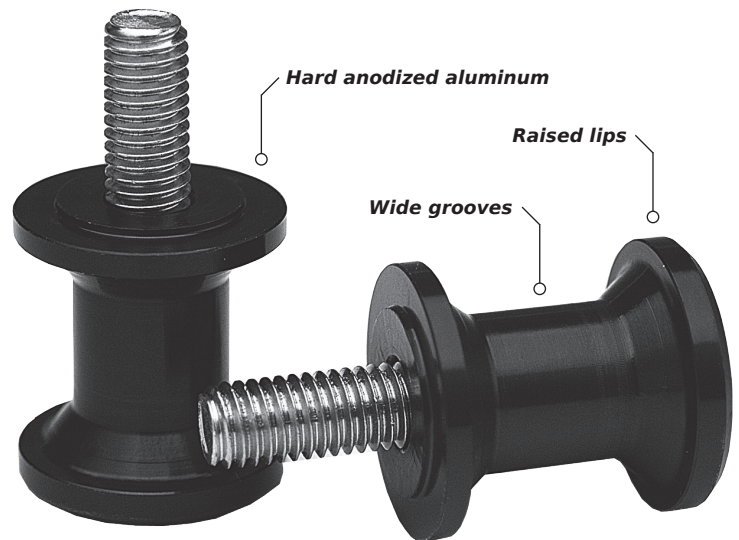

Delrin Swingarm Slider	Part Number
6mm	27-3600
8mm	27-3800
10mm	27-3100
10mm w/ 1mm offset	27-3110
10mm w/ 2mm offset	27-3120



Aluminum Swingarm Spools	Part Number
6mm Titanium	27-0600
6mm Black	27-0600B
6mm Blue	27-0600C
6mm Red	27-0600R
8mm Titanium	27-0800
8mm Black	27-0800B
8mm Blue	27-0800C

Common Spool Applications	Size (mm)	Common Spool Applications	Size (mm)
Aprilia RS250	6mm	Kawasaki ZX6R/636 2005-06	10mm
Aprilia Mille	10mm w/2 offset	Kawasaki ZX6RR 2007+	10mm w/2 offset
Aprillia Tuono	6mm	Kawasaki ZX9 1998-03	10mm
BMW S1000RR (need spacer both sides)	8mm*	Kawasaki ZX10R 2004-05	10mm w/1 offset
Honda CBR600RR (need spacer RHS)	8mm*	Kawasaki ZX10R 2006+	10mm w/2 offset
* = requires spacer Part # 27-27spacer			
Honda CBR929/954/1000RR	8mm	Kawasaki ZRX1100/1200	10mm w/2 offset
Honda RC51	8mm	Suzuki - All modern models	8mm
Kawasaki EX250 2008+	10mm	Triumph 675	6mm
Kawasaki 650R 2006+	10mm	Yamaha FZR	10mm
Kawasaki ZX6R/636 1998-04	10mm w/1 offset	Yamaha TZ250	10mm
		Yamaha R1 / R6	6mm

## Bodywork

When you want the best in bodywork you want Armour Bodies. In **Roadracing World's** test that featured the top 9 brands of bodywork Armour Bodies finished at the front of every major category! With "exceptional fit", finish, and offering "zero damage when flexed" you can see why Armour Bodies is a real "showstopper". For 2010 we offer both our award-winning Pro Series bodywork and our new top-flight Signature Series Elite bodywork. **The best just got better.**

### Ease of Installation

Nothing matters more than having bodywork fit properly. Armour Bodies produces each piece from **high-precision molds** with special resins that minimize shrinkage for the best possible fit.

### Ready to Finish

Armour Bodies comes with an industry leading urethane primer that needs only a light scuff and is **ready for paint**. This not only leads to beautiful finish but also saves a lot of preparation time.

### Flexible & Repairable

Originally created to withstand rocky impacts on lightweight racing kayaks our specially formulated resin provides superior flexibility and weight savings. This special resin also forms the best available bond with common fiberglass repair kits, giving you most durable repairs possible.

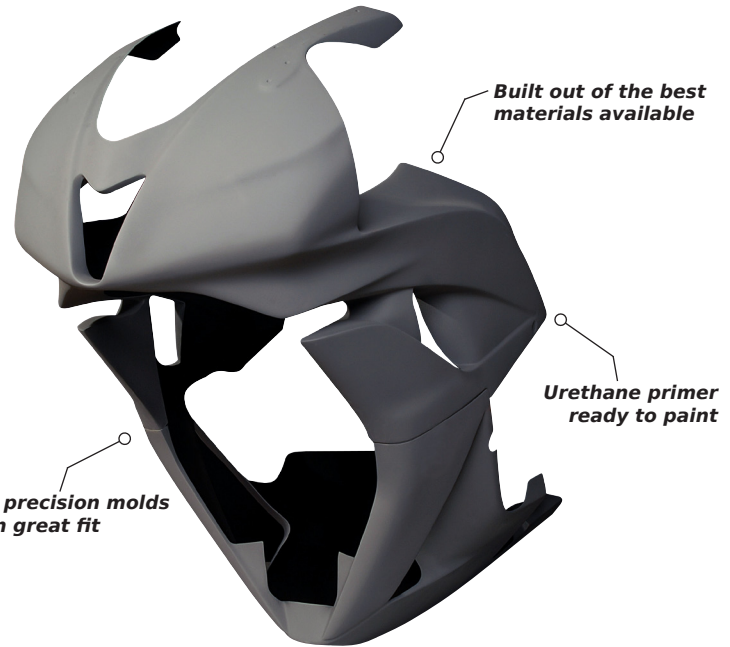

Signature Series' reinforced edges & mount points  
**An Armour Bodies Original!**

### Signature Series Elite

New for 2010 is the Armour Bodies Signature Series Elite.

Featuring all of the latest innovations in bodywork development the Signature Series Elite has:

- > **Unparalleled strength and durability** thanks to its carbon-kevlar reinforcements in all mounting areas.
- > Super trick primer that adds flexibility and has special paint absorption qualities to resist paint cracking upon flex.
- > Edges lined with a kevlar-strand to fight cracking at edges.
- > Super-light weight
- > **Note- Signature Series Elite is a Special Order and requires 1-2 weeks delivery time.**

*"The racer's budget means many of us do our own paintwork & fiberglass repairs... My Armour Bodies came ready to paint & sustained a lowside & multi-bike crash with minimal damage, giving me more time on the track than in the garage"* - Kitt Carella LRRS #53



## Full Coverage

Armour Bodies kits include: upper fairing, lower fairing, front fender, tail section (either SS or SB), and a draft shield (when applicable).

All of these pieces are available separately. (see Legend at right)

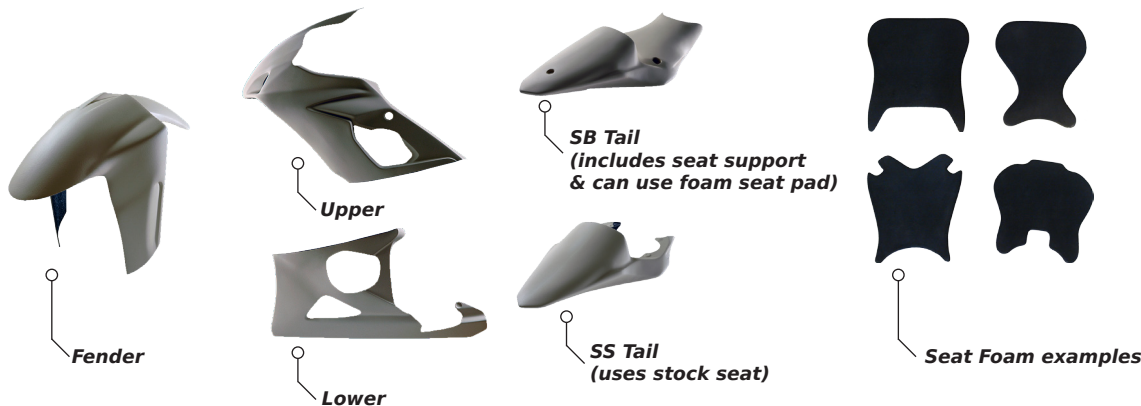

Legend	Part Suffix
Fender	F
Upper	U
Lower	L
SB Tail	SBT
SS Tail	SST
Seat Pad Foam	PAD
Draft Shield	D
Tank Cover	TC
Example	71-0700F

Model	Pro Series SS Kit	Pro Series SB Kit	Pro Series Ind. Part	Sig. Series SS Kit	Sig. Series SB Kit	Sig. Series Ind. Part	Notes
RS250	71-0700SS	-----	71-0700 +suffix	72-0700	-----	72-0700 +suffix	
RS50	71-0705SS	-----	71-0705 +suffix	72-0705	-----	72-0705 +suffix	Special order only
RSV4				TBA			

Model	Pro Series SS Kit	Pro Series SB Kit	Pro Series Ind. Part	Sig. Series SS Kit	Sig. Series SB Kit	Sig. Series Ind. Part	Notes
748 / 996 / 998	71-0610SS	-----	71-0610 +suffix	72-0610SS	-----	72-0610 +suffix	
749 / 999	71-0625SS	-----	71-0625 +suffix	72-0625SS	-----	72-0625 +suffix	
848 / 1098 / 1198	71-0640SS	71-0640SB	71-0640 +suffix	72-0640SS	72-0640SB	72-0640 +suffix	Optional Kit Ram Air Duct Avail. Suffix- BADL & BADR (left/right)

Model	Pro Series SS Kit	Pro Series SB Kit	Pro Series Ind. Part	Sig. Series SS Kit	Sig. Series SB Kit	Sig. Series Ind. Part	Notes
CBR600 F4	71-0330SS	-----	71-0330 +suffix	72-0330SS	-----	72-0330 +suffix	
CBR600 F4i	71-0332SS	-----	71-0332 +suffix	72-0332SS	-----	72-0332 +suffix	
CBR600RR 2003-04	-----	71-0335SB	71-0335 +suffix	-----	72-0335SB	72-0335 +suffix	Includes tank cover
CBR600RR 2005-06	-----	71-0336SB	71-0336 +suffix	-----	72-0336SB	72-0336 +suffix	Incl. tank cover & Ram Air Ducts Suffix- ADL & ADR (left/right)
CBR600RR 2007-08	71-0338SS	71-0338SB	71-0338 +suffix	72-0338SS	72-0338SB	72-0338 +suffix	Includes tank cover
CBR600RR 2009+	71-0348SS	71-0348SB	71-0348 +suffix	72-0348SS	72-0348SB	72-0348 +suffix	Includes tank cover
CBR1000RR 2008+	71-0339SS	71-0339SB	71-0339 +suffix	72-0339SS	72-0339SB	72-0339 +suffix	Includes tank cover
RC51	-----	71-0340SB	71-0340 +suffix	-----	72-0340SB	72-0340 +suffix	Tail designed for HRC subframe

Model	Pro Series SS Kit	Pro Series SB Kit	Pro Series Ind. Part	Sig. Series SS Kit	Sig. Series SB Kit	Sig. Series Ind. Part	Notes
Ninja EX250 2008+	71-0130SS	-----	71-0130 +suffix	72-0130SS	-----	72-0130 +suffix	
ZX6RR / 636 2005-06	71-0145SS	71-0145SB	71-0145 +suffix	72-0145SS	72-0145SB	72-0145 +suffix	
ZX6RR / 636 2007-08	71-0147SS	71-0147SB	71-0147 +suffix	72-0147SS	72-0147SB	72-0147 +suffix	
ZX6R 2009+	71-0149SS	71-0149SB	71-0149 +suffix	72-0149SS	72-0149SB	72-0149 +suffix	
ZX10R 2006-07	71-0165SS	71-0165SB	71-0165 +suffix	72-0165SS	72-0165SB	72-0165 +suffix	
ZX10R 2008-09	71-0167SS	71-0167SB	71-0167 +suffix	72-0167SS	72-0167SB	72-0167 +suffix	



# Armour Bodies

## Bodywork

Triumph	Model	Pro Series SS Kit	Pro Series SB Kit	Pro Series Ind. Part	Sig. Series SS Kit	Sig. Series SB Kit	Sig. Series Ind. Part	Notes
	675	71-0500SS	-----	71-0500 +suffix	72-0500SS	-----	72-0500 +suffix	Requires 06-08 windscreen

Suzuki	Model	Pro Series SS Kit	Pro Series SB Kit	Pro Series Ind. Part	Sig. Series SS Kit	Sig. Series SB Kit	Sig. Series Ind. Part	Notes
	SV650/S 1999-02	71-0220SS	-----	71-0220 +suffix	72-0220SS	-----	72-0220 +suffix	Includes 4-piece mount kit
	SV650/S 2003+	71-0224SS	-----	71-0224 +suffix	72-0224SS	-----	72-0224 +suffix	
	GSX-R600 2001-03	-----	71-0240SB	71-0240 +suffix	-----	72-0240SB	72-0240 +suffix	
	GSX-R600 2004-05	71-0242SS	71-0242SB	71-0242 +suffix	72-0242SS	72-0242SB	72-0242 +suffix	
	GSX-R600 2006-07	71-0247SS	71-0247SB	71-0247 +suffix	72-0247SS	72-0247SB	72-0247 +suffix	SB Tail incl. mount hardware
	GSX-R600 2008+	71-0248SS	71-0248SB	71-0248 +suffix	72-0248SS	72-0248SB	72-0248 +suffix	
	GSX-R750 2000-03	-----	71-0240SB	71-0240 +suffix	-----	72-0240SB	72-0240 +suffix	
	GSX-R750 2004-05	71-0242SS	71-0242SB	71-0242 +suffix	72-0242SS	72-0242SB	72-0242 +suffix	
	GSX-R750 2006-07	71-0247SS	71-0247SB	71-0247 +suffix	72-0247SS	72-0247SB	72-0247 +suffix	SB Tail incl. mount hardware
	GSX-R750 2008+	71-0248SS	71-0248SB	71-0248 +suffix	72-0248SS	72-0248SB	72-0248 +suffix	
	GSX-R1000 2005-06	71-0245SS	71-0245SB	71-0245 +suffix	72-0245SS	72-0245SB	72-0245 +suffix	
	GSX-R1000 2007-08	71-0249SS	71-0249SB	71-0249 +suffix	72-0249SS	72-0249SB	72-0249 +suffix	SB Tail incl. mount hardware
GSX-R1000 2009+	71-0250SS	71-0250SB	71-0250 +suffix	72-0250SS	72-0250SB	72-0250 +suffix	Kit includes side panels	

Yamaha	Model	Pro Series SS Kit	Pro Series SB Kit	Pro Series Ind. Part	Sig. Series SS Kit	Sig. Series SB Kit	Sig. Series Ind. Part	Notes
	R6 1999-02	71-0440SS	-----	71-0440 +suffix	72-0440SS	-----	72-0440 +suffix	
	R6 2003-05	71-0445SS	71-0445SB	71-0445 +suffix	72-0445SS	72-0445SB	72-0445 +suffix	
	R6 2006-07	71-0448SS	71-0448SB	71-0448 +suffix	72-0448SS	72-0448SB	72-0448 +suffix	
	R6 2008+	71-0449SS	71-0449SB	71-0449 +suffix	72-0449SS	72-0449SB	72-0449 +suffix	Includes upper mount brackets
	R1 2002-03	71-0420SS	-----	71-0420 +suffix	72-0420SS	-----	72-0420 +suffix	
	R1 2004-06	71-0425SS	-----	71-0425 +suffix	72-0425SS	-----	72-0425 +suffix	Includes tail mount spacer
	R1 2007-08	71-0428SS	71-0428SB	71-0428 +suffix	72-0428SS	72-0428SB	72-0428 +suffix	
R1 2009+	71-0452SS	71-0452SB	71-0452 +suffix	72-0452SS	72-0452SB	72-0452 +suffix		

### Custom Seat Foam Pads

Armour Bodies offers **custom cut seat foam for any motorcycle and bodywork available.** Our custom seat foam pads feature 15mm thick foam, special 3M adhesive glue, are hard-cut and finished.

> Please call for more information and ordering.



### Dzus Fasteners

Sold in sets of six (6), these clip-style fasteners work great to secure upper & lower fairings, under drafts and many other fairing connections. Top quality genuine Dzus product.



Product	Part Number
Dzus Kit (set of six)	71-Fastenerkit

*"Definitely the best bodywork I have ever used. The fit & finish are second to none...this is the only brand I would recommend"* - Brian Childree

The Staff at Woodcraft has been racing for a long time and have always felt that “Klucky Pucks” were the best in the business. We thought that this product line would be the perfect addition to the Woodcraft family and when the opportunity arose to add Klucky Pucks to our company we jumped at the chance!



Jeff Wood 11x ASRA #1

## Ranked #1

In recent years *Roadracing World* magazine did a comprehensive comparison of all the knee sliders on the market and Klucky Pucks came out **Number 1**.

## Durability

Pucks need to last; plain and simple! Klucky Pucks are constructed with a compound developed through years of experience, resulting is a puck that **last longer than the competition** while maintaining the feel that racers need.

## Security

If your kneepucks get knocked off while on the track you're in for a long day, and some leather repair. Klucky Pucks have the **toughest velcro on the market**, bar none!

Color	Part Number
Black	95-0100
Blue	95-0200
Yellow	95-0300
Red	95-0400
White	95-0500



## What do the Pro's say?

“Your pucks are the very best I’ve come across..”  
- Chris Carr

Your sliders last longer & slide smoother...without grabbing the pavement when I plant my knee” - Steve Crevier

These pucks last longer and stay on better than any puck I’ve ever tried” - Jeff Wood

“19 pucks tested, Overall comparison test winner”  
- Chris Ulrich



ECK Racing's Pete Gaboriault LRRS #187

*“After a whole year of abuse I’ve yet to replace my Klucky Pucks..& I got them used!” - Pete Gaboriault LRRS #187*



# Ceramic Bearings

## Wheel & Engine Kits

How do you get that Factory-Race bike advantage? One of the secrets is ceramic bearings that are used in nearly **every AMA Superbike, World Superbike, MotoGP, and Professional Drag Race motor** around the world! Less weight, less friction and less surface wear equals more horsepower in your motor, simple as that.

### Reduced Rotating Mass

The ceramic balls in these hybrid bearings are over **60% lighter** than their steel counterparts resulting in faster acceleration and reduced inertial loads.

### Low Friction - Less Vibration

The coefficient of friction for the ceramic balls is an average of 3x's lower than steel. When you combine this with the high tolerances for roundness you get a bearing that has dramatically lowers vibration levels and produces **more horsepower**.

### Preservation

Due to the unique properties of the ceramic balls these bearings have vastly reduced surface wear when compared to steel balls. The reduction in wear eliminates a large portion of the oil contaminates, thus prolonging lubricant life.



Make & Model	Engine Kit	Wheel Kit	Make & Model	Engine Kit	Wheel Kit
Honda CBR600RR 2003-06	20-0335E	20-0335W	Suzuki GSX-R600 2006+	20-0247E	20-0247W
Honda CBR600RR 2007+	20-0338E	20-0338W	Suzuki GSX-R750 2000-05	20-0240E	20-0240W
Honda CBR1000RR 2004-2007	20-0337E	20-0337W	Suzuki GSX-R750 2006+	20-0247E	20-0247W
Honda CBR1000RR 2008+	20-0339E	20-0339W	Suzuki GSX-R1000 2005-06	20-0245E	20-0245W
Kawasaki ZX6R / 636 2005-06	20-0145E	20-0145W	Suzuki GSX-R1000 2007-08	20-0249E	20-0249W
Kawasaki ZX6R 2007-08	20-0147E	20-0147W	Suzuki GSX-R1000 2009+	20-0250E	20-0250W
Kawasaki ZX6R 2009+	20-0149E	20-0149W	Yamaha R6 2003-05	20-0445E	20-0445W
Kawasaki ZX10R 2004-05	20-0160E	20-0160W	Yamaha R6 2006+	20-0449E	20-0449W
Kawasaki ZX10R 2006+	20-0165E	20-0165W	Yamaha R1 2004-2006	20-0425E	20-0425W
Suzuki SV650 / S 1999-02	20-0220E	20-0220W	Yamaha R1 2007-08	20-0428E	20-0428W
Suzuki SV650 / S 2003+	20-0224E	20-0224W	Yamaha R1 2009+	20-0452E	20-0452W
Suzuki GSX-R600 2001-05	20-0240E	20-0240W			



#### Note-

> This is just a partial listing of bikes and kits available. We offer Engine and Wheel kits for most makes and brands. If your bike isn't listed please call and we'll be happy to assist you: **978-297-2977**

### Real World Results

How do our Ceramic Bearing Kits perform in the Real World? To find out we compared results in a 2005 Yamaha R6 drag bike before and after with our Engine and Wheel kits installed. Post-installation the R6 ran a average **.15 seconds quicker** and had gained **2-3mph** through the trap!



Team Witchkraft WERA #48



Heading out for a Bike Night or need something to keep you warm for those chilly paddock nights? Woodcraft offers up some options to keep you looking good both on and off the bike. **NOTE-** Model not included with purchase.



Jen Ross USCRA #555

Woodcraft "Make Sense" tshirt & Woodcraft embroidered beanie



Woodcraft "W-Hoodie" embroidered heavyweight sweatshirt



Woodcraft "Make Sense" tshirt (back)

T-Shirt	Part Number	Hoodie	Part Number	Decals	Part Number	Other	Part Number
Small	99-0100S	Small	99-0200S	5.25" x 1.375"	99-0525	Beanie	99-0300
Medium	99-0100M	Medium	99-0200M	10.625" x 2.813"	99-010625	Duffel Bag	31-2500
Large	99-0100L	Large	99-0200L	14.375" x 3.875"	99-014375	Banner 12"x60"	99-BANNER
Xtra-Large	99-0100XL	Xtra-Large	99-0200XL	Armour Bodies		Patch	99-PATCH
Double XL	99-0100XXL	Double-XL	99-0200XXL				

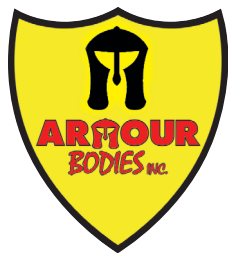

Armour Bodies decal  
2.75" x 3.50"



**Top**  
Woodcraft decal  
5.25" x 1.375"  
10.625" x 2.813"  
14.375" x 3.875"

**Bottom**  
Woodcraft patch  
5.375" x 1.5"



**Detail**  
Woodcraft embroidered beanie

**Not Shown**  
Woodcraft Pit Banner  
60" x 12"  
(graphics similar to decal)



Woodcraft Duffel Bag  
16" x 10" x 12"



# Thank You

We just wanted to say thanks to everyone that supports Woodcraft Technologies and allowing us to continue building quality parts for your sportbike. Here's a few photos of those who enjoy our products. Sorry we couldn't included everyone! See you at the track!



*Thank you for choosing Woodcraft. Keep the rubber side down!*

Woodcraft will be introducing products for the new 2010 model motorcycles all season long. We have left this area for you to make notes of the prices and part numbers on new model applications as they become available.

Model	Part Type	Part Number	Dealer	Retail

## *Terms & Conditions*

### **Ordering**

**Phone:** 978-297-2977 Monday-Friday 9:00am to 5:00pm EST

**Fax:** 24 hours at 978-297-2922

**Online:** 24 hours at <http://www.woodcraft-cfm.com> (both Dealer and Retail accounts available)

### **Payment Terms**

All orders will be shipped either prepaid or COD unless other arrangements have been made. Woodcraft reserves the right to specify collection by certified check, money order, or company check. Personal checks are not accepted. Credit card orders must be shipped to the billing address of the credit card.

### **Returns**

No item will be accepted without prior approval. All returns must be authorized within fifteen (15) days of receipt of order. All returns must be accompanied with a return authorization (RA) number and must be in new and unused condition. All returns are subject to a restocking fee of 20%. Returns must have a clearly marked RA number and customer name on the outside of the box. No returns will be accepted on close-out or special order items.

### **Liability**

The items in this catalog are intended for racing use and may render some vehicles illegal for street riding in some States. The purchaser is responsible for familiarity of the local and national laws pertaining to the use of any Woodcraft products. The purchaser of any part releases the manufacturer of those parts and Woodcraft from all liabilities pertaining to the use of the parts. The purchaser recognizes that any modifications to any motorcycle can increase the risk of an accident and/or injury and may also render the motorcycle illegal for use on public roads. Installation of all Woodcraft products should be performed by trained professionals.

### **Warning**

Installation and use of some Woodcraft Technologies, Inc. products will change the response of the motorcycle to rider control inputs. Failure of the rider to adapt to these changes may cause loss of control and serious injury or death. Improper installation and/or failure to comply with all warning and instructions may cause a loss of control and serious injury or death. **Do not install or use any Woodcraft Technologies, Inc. product if you are unable to do so in compliance of all instructions and warnings. Seek the assistance of a trained professional technician.**





# WOODCRAFT

*Technologies, Inc.*

105 Baldwinville Road  
 Winchendon, MA 01475  
 978-297-2977  
 978-297-2922

[www.woodcraft-cfm.com](http://www.woodcraft-cfm.com)  
[info@woodcraft-cfm.com](mailto:info@woodcraft-cfm.com)

